

MICROBORE MGAH07 GEAR ADJUST BORING HEADS



Supplied with thro' coolant holes.
For use on standard ADE2248 adaptors

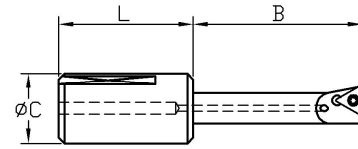
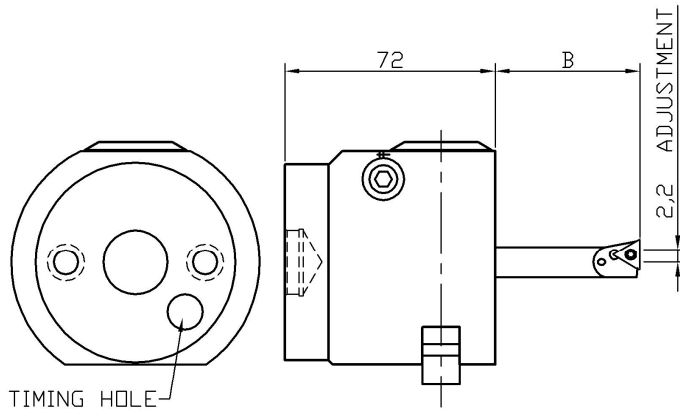

FIGURE 1
TRIANGULAR INSERT

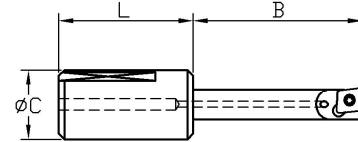

FIGURE 2
RHOMBOIDAL INSERT

MGAH07 Details								
Microbore Part No.	Boring Range		B Boring Length	Ø C	L	Boring Tool	Insert Type	
	A						Fig.	Insert
	Min	Max						
MGAH07-2248	7.0	11.0	29.0	12.0	41.0	BTT12-07-29	1	TB__0601__
						BTS12-07-29	2	EP__0402__
	11.0	15.0	35.0	12.0	41.0	BTC12-11-35	2	CC__09T3__
						BTS12-11-35	2	EP__0602__
	15.0	19.0	64.0	12.0	41.0	BTC12-15-64	2	CC__09T3__
						BTS12-15-64	2	EP__0803__
	19.0	23.0	70.0	12.0	41.0	BTC12-19-70	2	CC__09T3__
						BTS12-19-70	2	EP__0803__
	23.0	27.0	70.0	12.0	41.0	BTC12-23-70	2	CC__09T3__
						BTS12-23-70	2	EP__0803__

NOTE: HEADS, ADAPTORS AND BORING TOOLS MUST BE ORDERED SEPARATELY.



REFER TO MICROBORE ADAPTOR RANGE CATALOGUE FOR ADE2248 ADAPTOR DETAILS.

MICROBORE STRONGLY ADVISE THAT ANY RECONDITIONING WORK ON GEAR ADJUST BORING BARS OR BORING RINGS IS CARRIED OUT BY FACTORY TRAINED TECHNICIANS.